

Question:

A **Widlar current source** circuit to be designed has the configuration shown in **Figure 1**. The circuit parameters are: $V^+ = +5.5 \text{ V}$ and $V^- = -5.5 \text{ V}$. The transistor parameters are: $V_{BE1} = 0.6 \text{ V}$, $V_A = 80 \text{ V}$, and $\beta = 120$ (Therefore, we can assume that $I_C \approx I_E$).

- (a) Design the Widlar current source circuit such that $I_{REF} = 1 \text{ mA}$ and $I_O = 12 \mu\text{A}$. [4 marks]
 (b) Find V_{BE2} . [2 marks]
 (c) The output resistance (R_O) of the Widlar current source in **Figure 1** can be calculated using the following formula.

$$R_O = r_{o2} \left[1 + g_{m2} (R_E \parallel r_{\pi 2}) \right]$$

If the Widlar current source circuit in **Figure 1** is used as an **active load** in a common-emitter BJT amplifier, what is the value of the **load resistance** provided by the Widlar current source? Use parameters and results from **part (a)** above. [4 marks]

Answer:

(a)

$$R_1 = \frac{V^+ - V_{BE1} - V^-}{I_{REF}} = \frac{5.5 - 0.6 - (-5.5)}{1\text{m}} = 10.4\text{k}\Omega \quad [2]$$

$$R_E = \frac{V_T}{I_O} \ln \left(\frac{I_{REF}}{I_O} \right) = \frac{0.026}{12\mu} \ln \left(\frac{1\text{m}}{12\mu} \right) = 9.58\text{k}\Omega \quad [2]$$

(b)

$$V_{BE2} = V_{BE1} - I_O R_E = 0.6 - (12\mu)(9.58\text{k}) = 0.485\text{V} \quad [2]$$

(c)

$$g_{m2} = \frac{I_O}{V_T} = \frac{12\mu}{0.026} = 0.462\text{mA/V} \quad [1]$$

$$r_{\pi 2} = \frac{\beta V_T}{I_O} = \frac{(120)(0.026)}{12\mu} = 260\text{k}\Omega \quad [1]$$

$$r_{o2} = \frac{V_A}{I_O} = \frac{80}{12\mu} = 6.67\text{M}\Omega \quad [1]$$

$$R_O = r_{o2} \left[1 + g_{m2} (R_E \parallel r_{\pi 2}) \right]$$

$$R_O = (6.67\text{M}) \left[1 + (0.462\text{m})(9.58\text{k} \parallel 260\text{k}) \right] = 35.1\text{M}\Omega \quad [1]$$

Figure 1

Question:

A **Widlar current source** circuit to be designed has the configuration shown in **Figure 1**. The circuit parameters are: $V^+ = +5.0 \text{ V}$ and $V^- = -5.0 \text{ V}$. The transistor parameters are: $V_{BE1} = 0.6 \text{ V}$, $V_A = 80 \text{ V}$, and $\beta = 120$ (Therefore, we can assume that $I_C \approx I_E$).

- (a) Design the Widlar current source circuit such that $I_{REF} = 1.2 \text{ mA}$ and $I_O = 12 \mu\text{A}$. [4 marks]
 (b) Find V_{BE2} . [2 marks]
 (c) The output resistance (R_O) of the Widlar current source in **Figure 1** can be calculated using the following formula.

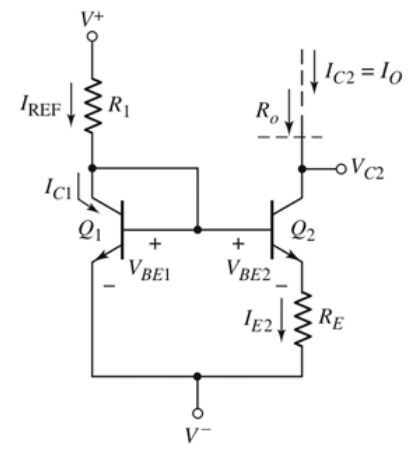
$$R_O = r_{o2} \left[1 + g_{m2} (R_E \parallel r_{\pi 2}) \right]$$

If the Widlar current source circuit in **Figure 1** is used as an **active load** in a common-emitter BJT amplifier, what is the value of the **load resistance** provided by the Widlar current source? Use parameters and results from **part (a)** above. [4 marks]

Answer:

(a)

$$R_1 = \frac{V^+ - V_{BE1} - V^-}{I_{REF}} = \frac{5 - 0.6 - (-5)}{1.2\text{m}} = 7.83\text{k}\Omega \quad [2]$$

$$R_E = \frac{V_T}{I_O} \ln\left(\frac{I_{REF}}{I_O}\right) = \frac{0.026}{12\mu} \ln\left(\frac{1.2\text{m}}{12\mu}\right) = 9.98\text{k}\Omega \quad [2]$$

(b)

$$V_{BE2} = V_{BE1} - I_O R_E = 0.6 - (12\mu)(9.98\text{k}) = 0.48\text{V} \quad [2]$$

(c)

$$g_{m2} = \frac{I_O}{V_T} = \frac{12\mu}{0.026} = 0.462\text{mA/V} \quad [1]$$

$$r_{\pi 2} = \frac{\beta V_T}{I_O} = \frac{(120)(0.026)}{12\mu} = 260\text{k}\Omega \quad [1]$$

$$r_{o2} = \frac{V_A}{I_O} = \frac{80}{12\mu} = 6.67\text{M}\Omega \quad [1]$$

$$R_O = r_{o2} \left[1 + g_{m2} (R_E \parallel r_{\pi 2}) \right] \quad [1]$$

$$R_O = (6.67\text{M}) \left[1 + (0.462\text{m})(9.98\text{k} \parallel 260\text{k}) \right] = 36.2\text{M}\Omega \quad [1]$$

Figure 1

EEEE273 - Quiz 2 [Question Set 3]
 SEMESTER 2, ACADEMIC YEAR 2011/2012
 Date: 12 October 2011

Question:

A **Widlar current source** circuit to be designed has the configuration shown in **Figure 1**. The circuit parameters are: $V^+ = +5.0 \text{ V}$ and $V^- = -5.0 \text{ V}$. The transistor parameters are: $V_{BE1} = 0.6 \text{ V}$, $V_A = 100 \text{ V}$, and $\beta = 120$ (Therefore, we can assume that $I_C \approx I_E$).

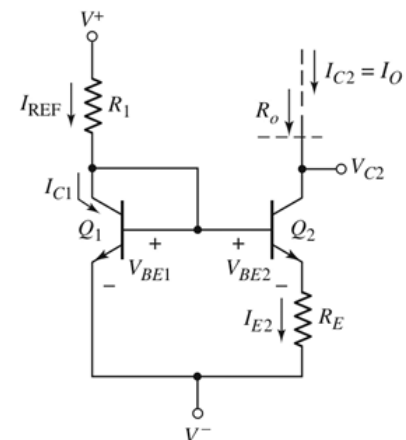
- (a) Design the Widlar current source circuit such that $I_{REF} = 1 \text{ mA}$ and $I_O = 10 \mu\text{A}$. [4 marks]
 (b) Find V_{BE2} . [2 marks]
 (c) The output resistance (R_O) of the Widlar current source in **Figure 1** can be calculated using the following formula.

$$R_O = r_{o2} \left[1 + g_{m2} (R_E \parallel r_{\pi 2}) \right]$$

If the Widlar current source circuit in **Figure 1** is used as an **active load** in a common-emitter BJT amplifier, what is the value of the **load resistance** provided by the Widlar current source? Use parameters and results from **part (a)** above. [4 marks]

Answer:

(a)

$$R_1 = \frac{V^+ - V_{BE1} - V^-}{I_{REF}} = \frac{5 - 0.6 - (-5)}{1\text{m}} = 9.40\text{k}\Omega \quad [2]$$

$$R_E = \frac{V_T}{I_O} \ln \left(\frac{I_{REF}}{I_O} \right) = \frac{0.026}{10\mu} \ln \left(\frac{1\text{m}}{10\mu} \right) = 11.97\text{k}\Omega \quad [2]$$

(b)

$$V_{BE2} = V_{BE1} - I_O R_E = 0.6 - (10\mu)(11.97\text{k}) = 0.48\text{V} \quad [2]$$

(c)

$$g_{m2} = \frac{I_O}{V_T} = \frac{10\mu}{0.026} = 0.385\text{mA/V} \quad [1]$$

$$r_{\pi 2} = \frac{\beta V_T}{I_O} = \frac{(120)(0.026)}{10\mu} = 312\text{k}\Omega \quad [1]$$

$$r_{o2} = \frac{V_A}{I_O} = \frac{100}{10\mu} = 10.0\text{M}\Omega \quad [1]$$

$$R_O = r_{o2} \left[1 + g_{m2} (R_E \parallel r_{\pi 2}) \right]$$

$$R_O = (10.0\text{M}) \left[1 + (0.385\text{m})(11.97\text{k} \parallel 312\text{k}) \right] = 54.3\text{M}\Omega \quad [1]$$

Figure 1

EEEE273 - Quiz 2 [Question Set 4]
 SEMESTER 2, ACADEMIC YEAR 2011/2012
 Date: 12 October 2011

Question:

A **Widlar current source** circuit to be designed has the configuration shown in **Figure 1**. The circuit parameters are: $V^+ = +5.5 \text{ V}$ and $V^- = -5.5 \text{ V}$. The transistor parameters are: $V_{BE1} = 0.6 \text{ V}$, $V_A = 100 \text{ V}$, and $\beta = 120$ (Therefore, we can assume that $I_C \approx I_E$).

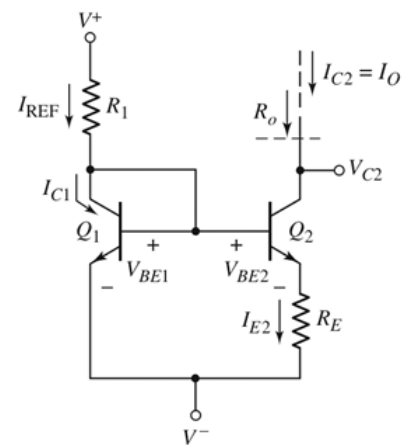
- (a) Design the Widlar current source circuit such that $I_{REF} = 1 \text{ mA}$ and $I_O = 10 \mu\text{A}$. [4 marks]
 (b) Find V_{BE2} . [2 marks]
 (c) The output resistance (R_O) of the Widlar current source in **Figure 1** can be calculated using the following formula.

$$R_O = r_{o2} \left[1 + g_{m2} (R_E \parallel r_{\pi 2}) \right]$$

If the Widlar current source circuit in **Figure 1** is used as an **active load** in a common-emitter BJT amplifier, what is the value of the **load resistance** provided by the Widlar current source? Use parameters and results from **part (a)** above. [4 marks]

Answer:

(a)

$$R_1 = \frac{V^+ - V_{BE1} - V^-}{I_{REF}} = \frac{5.5 - 0.6 - (-5.5)}{1\text{m}} = 10.4\text{k}\Omega \quad [2]$$

$$R_E = \frac{V_T}{I_O} \ln\left(\frac{I_{REF}}{I_O}\right) = \frac{0.026}{10\mu} \ln\left(\frac{1\text{m}}{10\mu}\right) = 11.97\text{k}\Omega \quad [2]$$

(b)

$$V_{BE2} = V_{BE1} - I_O R_E = 0.6 - (10\mu)(11.97\text{k}) = 0.48\text{V} \quad [2]$$

(c)

$$g_{m2} = \frac{I_O}{V_T} = \frac{10\mu}{0.026} = 0.385\text{mA/V} \quad [1]$$

$$r_{\pi 2} = \frac{\beta V_T}{I_O} = \frac{(120)(0.026)}{10\mu} = 312\text{k}\Omega \quad [1]$$

$$r_{o2} = \frac{V_A}{I_O} = \frac{100}{10\mu} = 10.0\text{M}\Omega \quad [1]$$

$$R_O = r_{o2} \left[1 + g_{m2} (R_E \parallel r_{\pi 2}) \right]$$

$$R_O = (10.0\text{M}) \left[1 + (0.385\text{m})(11.97\text{k} \parallel 312\text{k}) \right] = 54.3\text{M}\Omega \quad [1]$$

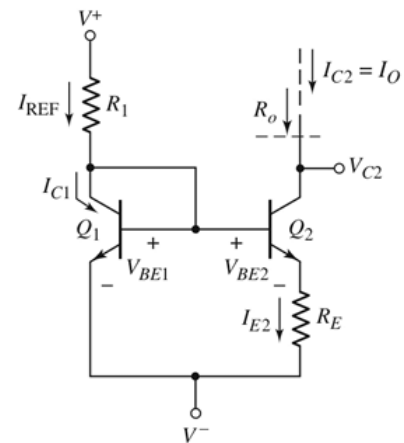

Figure 1