

**Question:**

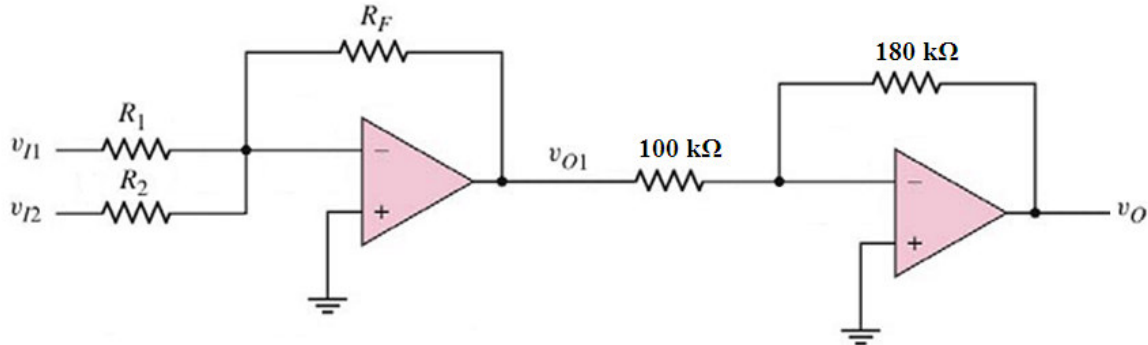

**Figure 1**

Refer to **Figure 1**.

(a) Using **superposition theorem** and **ideal op-amp properties**, determine  $v_{O1}$  when  $R_1 = 10 \text{ k}\Omega$ ,  $R_2 = 24 \text{ k}\Omega$ ,  $R_F = 30 \text{ k}\Omega$ ,  $v_{I1} = 25 \text{ mV}$ , and  $v_{I2} = -10 \text{ mV}$ .

[8 marks]

(b) Find  $v_O$ .

[2 marks]

Show clearly all calculations in order to get full marks.

**Answers:**

(a)

**Superposition theorem:**

$$v_{I2} = 0, \quad v_{O1}(v_{I1}) = -(R_F / R_1)(v_{I1}) = -(30\text{k}/10\text{k})(25\text{m}) = -75 \text{ mV} \quad [3]$$

$$v_{I1} = 0, \quad v_{O1}(v_{I2}) = -(R_F / R_2)(v_{I2}) = -(30\text{k}/24\text{k})(-10\text{m}) = 12.5 \text{ mV} \quad [3]$$

$$v_{O1} = v_{O1}(v_{I1}) + v_{O1}(v_{I2}) = (-75\text{m}) + (12.5\text{m}) = -62.5 \text{ mV} \quad [2]$$

(b)

$$v_O = -(180\text{k}/100\text{k})(v_{O1}) = -(180\text{k}/100\text{k})(-62.5\text{m}) = 112.5 \text{ mV} \quad [2]$$

**Question:**

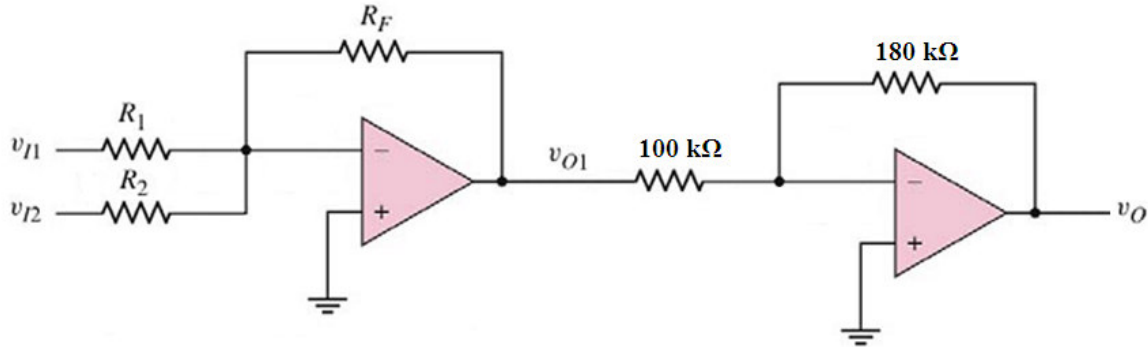

**Figure 1**

Refer to **Figure 1**.

(a) Using **superposition theorem** and **ideal op-amp properties**, determine  $v_{O1}$  when  $R_1 = 15 \text{ k}\Omega$ ,  $R_2 = 20 \text{ k}\Omega$ ,  $R_F = 30 \text{ k}\Omega$ ,  $v_{I1} = -25 \text{ mV}$ , and  $v_{I2} = 20 \text{ mV}$ .

[8 marks]

(b) Find  $v_O$ .

[2 marks]

Show clearly all calculations in order to get full marks.

**Answers:**

(a)

**Superposition theorem:**

$$v_{I2} = 0, \quad v_{O1}(v_{I1}) = -(R_F / R_1)(v_{I1}) = -(30\text{k}/15\text{k})(-25\text{m}) = 50 \text{ mV} \quad [3]$$

$$v_{I1} = 0, \quad v_{O1}(v_{I2}) = -(R_F / R_2)(v_{I2}) = -(30\text{k}/20\text{k})(20\text{m}) = -30 \text{ mV} \quad [3]$$

$$v_{O1} = v_{O1}(v_{I1}) + v_{O1}(v_{I2}) = (50\text{m}) + (-30\text{m}) = 20 \text{ mV} \quad [2]$$

(b)

$$v_O = -(180\text{k}/100\text{k})(v_{O1}) = -(180\text{k}/100\text{k})(20\text{m}) = -36 \text{ mV} \quad [2]$$

EEEE273 - Quiz 6 [Question Set 3]  
 SEMESTER 2, ACADEMIC YEAR 2011/2012  
 Date: 14 December 2011

**Question:**

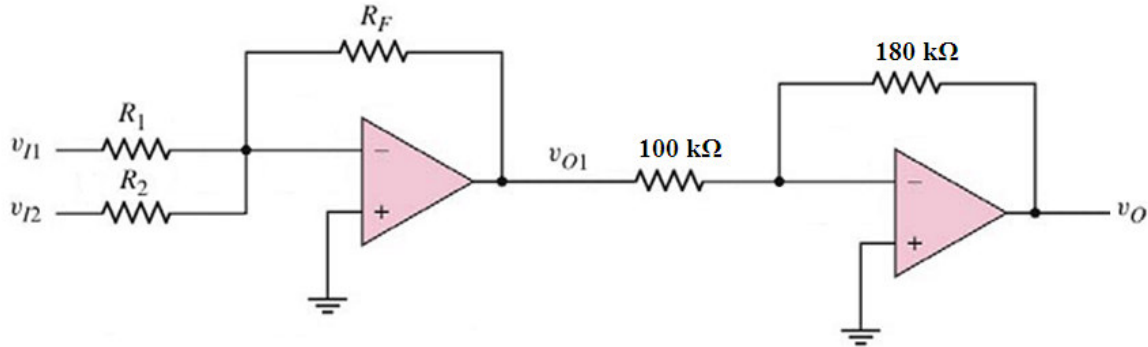

**Figure 1**

Refer to **Figure 1**.

(a) Using **superposition theorem** and **ideal op-amp properties**, determine  $v_{O1}$  when  $R_1 = 12 \text{ k}\Omega$ ,  $R_2 = 20 \text{ k}\Omega$ ,  $R_F = 24 \text{ k}\Omega$ ,  $v_{I1} = 15 \text{ mV}$ , and  $v_{I2} = -20 \text{ mV}$ .

[8 marks]

(b) Find  $v_O$ .

[2 marks]

Show clearly all calculations in order to get full marks.

**Answers:**

(a)

**Superposition theorem:**

$$v_{I2} = 0, \quad v_{O1}(v_{I1}) = -(R_F / R_1)(v_{I1}) = -(24\text{k}/12\text{k})(15\text{m}) = -30 \text{ mV} \quad [3]$$

$$v_{I1} = 0, \quad v_{O1}(v_{I2}) = -(R_F / R_2)(v_{I2}) = -(24\text{k}/20\text{k})(-20\text{m}) = 24 \text{ mV} \quad [3]$$

$$v_{O1} = v_{O1}(v_{I1}) + v_{O1}(v_{I2}) = (-30\text{m}) + (24\text{m}) = -6 \text{ mV} \quad [2]$$

(b)

$$v_O = -(180\text{k}/100\text{k})(v_{O1}) = -(180\text{k}/100\text{k})(-6\text{m}) = 10.8 \text{ mV} \quad [2]$$

EEEE273 - Quiz 6 [Question Set 4]  
 SEMESTER 2, ACADEMIC YEAR 2011/2012  
 Date: 14 December 2011

**Question:**

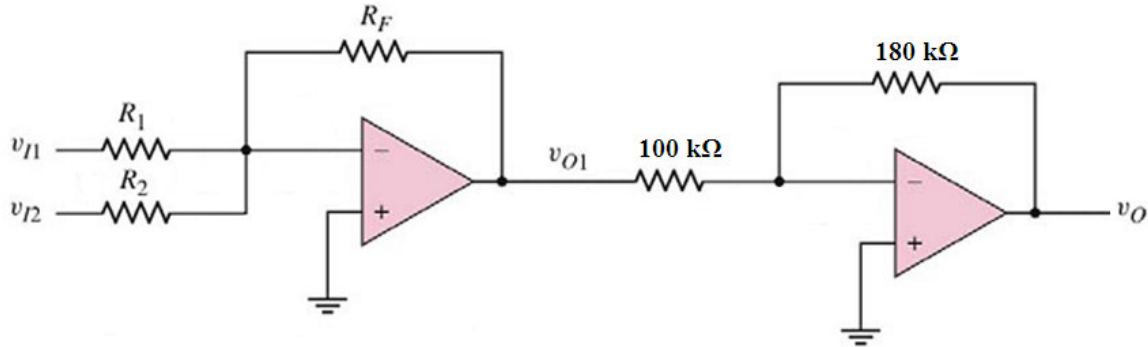

Figure 1

Refer to Figure 1.

(a) Using **superposition theorem** and **ideal op-amp properties**, determine  $v_{O1}$  when  $R_1 = 20 \text{ k}\Omega$ ,  $R_2 = 10 \text{ k}\Omega$ ,  $R_F = 33 \text{ k}\Omega$ ,  $v_{I1} = -15 \text{ mV}$ , and  $v_{I2} = 40 \text{ mV}$ .

[8 marks]

(b) Find  $v_O$ .

[2 marks]

Show clearly all calculations in order to get full marks.

**Answers:**

(a)

**Superposition theorem:**

$$v_{I2} = 0, \quad v_{O1}(v_{I1}) = -(R_F / R_1)(v_{I1}) = -(33\text{k}/20\text{k})(-15\text{m}) = 24.75 \text{ mV} \quad [3]$$

$$v_{I1} = 0, \quad v_{O1}(v_{I2}) = -(R_F / R_2)(v_{I2}) = -(33\text{k}/10\text{k})(40\text{m}) = -132 \text{ mV} \quad [3]$$

$$v_{O1} = v_{O1}(v_{I1}) + v_{O1}(v_{I2}) = (24.75\text{m}) + (-132\text{m}) = -107.25 \text{ mV} \quad [2]$$

(b)

$$v_O = -(180\text{k}/100\text{k})(v_{O1}) = -(180\text{k}/100\text{k})(-107.25\text{m}) = -193.05 \text{ mV} \quad [2]$$