

Question:

Study the simple output stage circuit shown in **Figure 1** carefully. Let $R_1 = 50 \text{ k}\Omega$, $R_2 = 5 \text{ k}\Omega$, $I_{C2} = 0.5 \text{ mA}$, and $I_{C3} = 1 \text{ mA}$. The transistor parameters are: $\beta = 100$ and $V_A = 120 \text{ V}$. Neglect base currents.

Determine the output resistance (R_O) of the emitter follower Q_3 . [10 marks]

Write your answer **using pen**, in 4 decimal points, with **proper Units** for all the parameters.

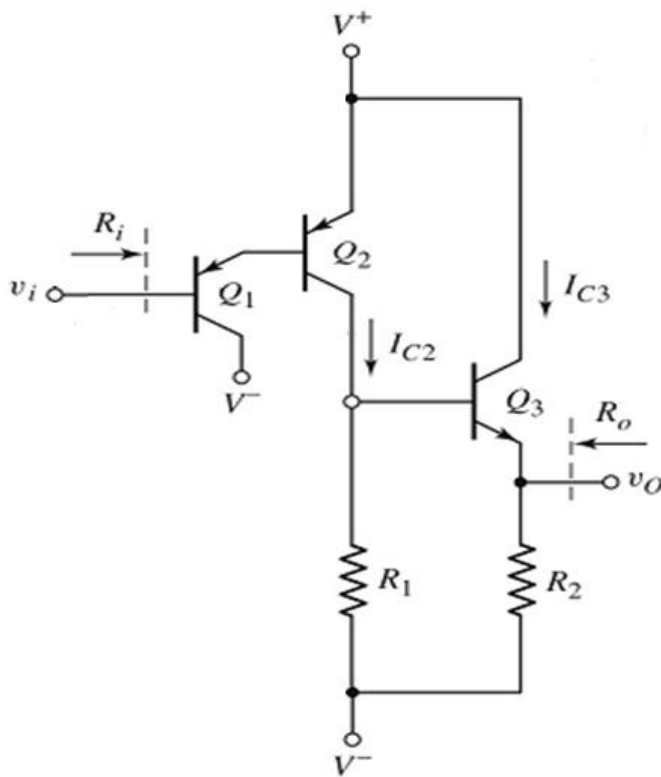

Figure 1

$$i_C = I_S e^{v_{BE}/V_T}; \text{npn}$$

$$i_C = I_S e^{v_{EB}/V_T}; \text{pnp}$$

$$i_C = \alpha i_E = \beta i_B$$

$$i_E = i_B + i_C$$

$$\alpha = \frac{\beta}{\beta + 1}$$

; Small signal

$$\beta = g_m r_\pi$$

$$r_\pi = \frac{\beta V_T}{I_{CQ}}$$

$$g_m = \frac{I_{CQ}}{V_T}$$

$$r_o = \frac{V_A}{I_{CQ}}$$

$$V_T = 26 \text{ mV}$$

R_O	$= R_2 \parallel [(r_{\pi 3} + Z) / (1 + \beta)]$	[1.5]
Z	$= R_1 \parallel R_{c2}$	[1]
R_{c2}	$= r_{o2} = V_A / I_{C2}$	[2]
	$= (120 \text{ V}) / (0.5 \text{ mA}) = 240 \text{ k}\Omega$	[1]
Z	$= (50 \text{ k}\Omega) \parallel (240 \text{ k}\Omega) = 41.379 \text{ k}\Omega$	[1]
$r_{\pi 3}$	$= (\beta V_T) / I_{C3} = (100 \times 0.026) / 1\text{m} = 2.6 \text{ k}\Omega$	[2]
R_O	$= (5 \text{ k}\Omega) \parallel [(2.6 \text{ k}\Omega + 41.379 \text{ k}\Omega) / (1 + 100)]$	[1]
	$= 400.55 \Omega$	[0.5]

EEEE273 - Quiz 3
 SEMESTER 1, ACADEMIC YEAR 2013/2014
 Date: 29 July 2013 Time: 15 minutes

Question:

Study the simple output stage circuit shown in **Figure 1** carefully. Let $R_1 = 40 \text{ k}\Omega$, $R_2 = 8 \text{ k}\Omega$, $I_{C2} = 0.4 \text{ mA}$, and $I_{C3} = 1 \text{ mA}$. The transistor parameters are: $\beta = 100$ and $V_A = 120 \text{ V}$. Neglect base currents.

Determine the output resistance (R_O) of the emitter follower Q_3 . [10 marks]

Write your answer using pen, in 4 decimal points, with **proper Units** for all the parameters.

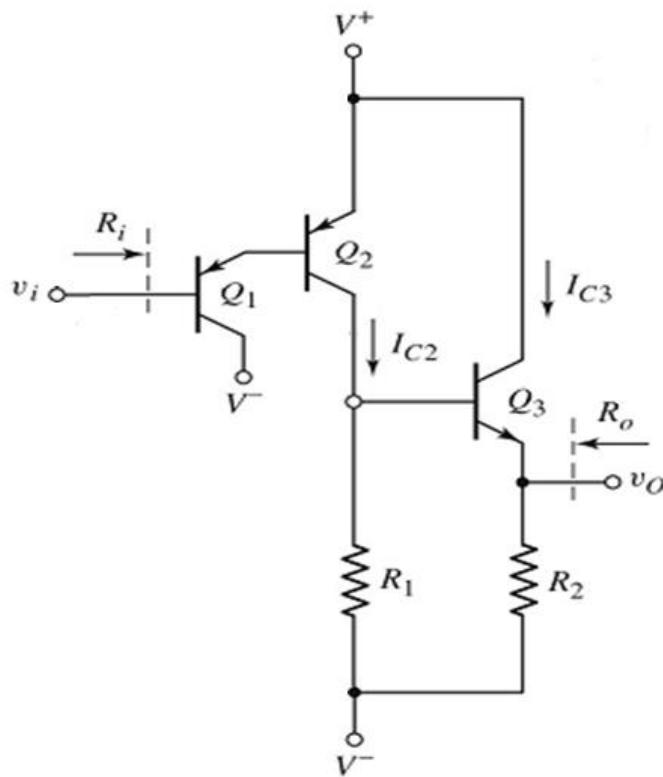

Figure 1

$$i_C = I_S e^{v_{BE}/V_T}; \text{npn}$$

$$i_C = I_S e^{v_{EB}/V_T}; \text{pnp}$$

$$i_C = \alpha i_E = \beta i_B$$

$$i_E = i_B + i_C$$

$$\alpha = \frac{\beta}{\beta + 1}$$

; Small signal

$$\beta = g_m r_\pi$$

$$r_\pi = \frac{\beta V_T}{I_{CQ}}$$

$$g_m = \frac{I_{CQ}}{V_T}$$

$$r_o = \frac{V_A}{I_{CQ}}$$

$$V_T = 26 \text{ mV}$$

R_O	$= R_2 \parallel [(r_{\pi 3} + Z) / (1 + \beta)]$	[1.5]
Z	$= R_1 \parallel R_{c2}$	[1]
R_{c2}	$= r_{O2} = V_A / I_{C2}$	[2]
	$= (120 \text{ V}) / (0.4 \text{ mA}) = 300 \text{ k}\Omega$	[1]
Z	$= (40 \text{ k}\Omega) \parallel (300 \text{ k}\Omega) = 35.294 \text{ k}\Omega$	[1]
$r_{\pi 3}$	$= (\beta V_T) / I_{C3} = (100 \times 0.026) / 1\text{m} = 2.6 \text{ k}\Omega$	[2]
R_O	$= (8 \text{ k}\Omega) \parallel [(2.6 \text{ k}\Omega + 35.294 \text{ k}\Omega) / (1 + 100)]$	[1]
	$= 358.38 \Omega$	[0.5]

Question:

Study the simple output stage circuit shown in **Figure 1** carefully. Let $R_1 = 55 \text{ k}\Omega$, $R_2 = 8 \text{ k}\Omega$, $I_{C2} = 0.3 \text{ mA}$, and $I_{C3} = 1 \text{ mA}$. The transistor parameters are: $\beta = 100$ and $V_A = 120 \text{ V}$. Neglect base currents.

Determine the output resistance (R_O) of the emitter follower Q_3 . [10 marks]

Write your answer **using pen**, in 4 decimal points, with **proper Units** for all the parameters.

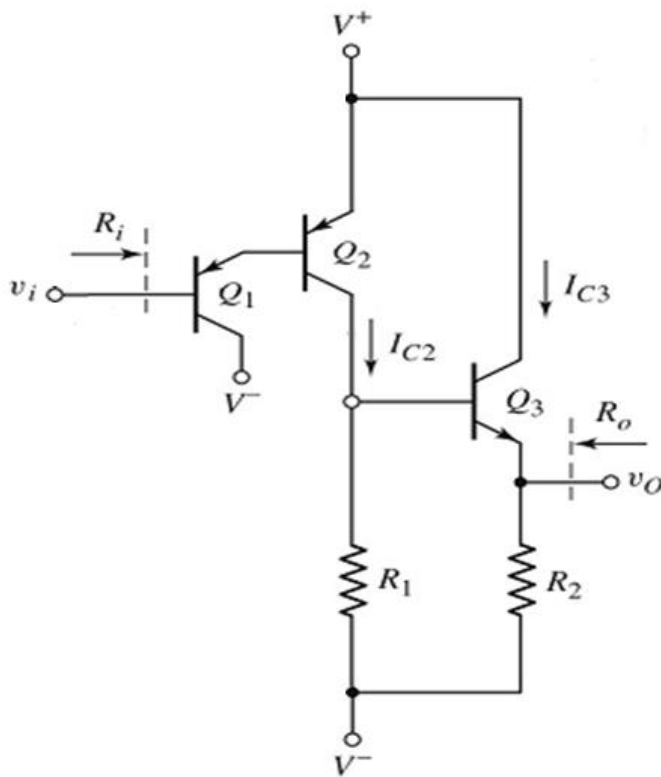

Figure 1

$$i_C = I_S e^{v_{BE}/V_T}; \text{npn}$$

$$i_C = I_S e^{v_{EB}/V_T}; \text{pnp}$$

$$i_C = \alpha i_E = \beta i_B$$

$$i_E = i_B + i_C$$

$$\alpha = \frac{\beta}{\beta + 1}$$

; Small signal

$$\beta = g_m r_\pi$$

$$r_\pi = \frac{\beta V_T}{I_{CQ}}$$

$$g_m = \frac{I_{CQ}}{V_T}$$

$$r_o = \frac{V_A}{I_{CQ}}$$

$$V_T = 26 \text{ mV}$$

R_O	$= R_2 \parallel [(r_{\pi 3} + Z) / (1 + \beta)]$	[1.5]
Z	$= R_1 \parallel R_{c2}$	[1]
R_{c2}	$= r_{o2} = V_A / I_{C2}$	[2]
	$= (120 \text{ V}) / (0.3 \text{ mA}) = 400 \text{ k}\Omega$	[1]
Z	$= (55 \text{ k}\Omega) \parallel (400 \text{ k}\Omega) = 48.351 \text{ k}\Omega$	[1]
$r_{\pi 3}$	$= (\beta V_T) / I_{C3} = (100 \times 0.026) / 1 \text{ m} = 2.6 \text{ k}\Omega$	[2]
R_O	$= (8 \text{ k}\Omega) \parallel [(2.6 \text{ k}\Omega + 48.351 \text{ k}\Omega) / (1 + 100)]$	[1]
	$= 474.55 \Omega$	[0.5]

Question:

Study the simple output stage circuit shown in **Figure 1** carefully. Let $R_1 = 45 \text{ k}\Omega$, $R_2 = 10 \text{ k}\Omega$, $I_{C2} = 0.6 \text{ mA}$, and $I_{C3} = 1 \text{ mA}$. The transistor parameters are: $\beta = 100$ and $V_A = 120 \text{ V}$. Neglect base currents.

Determine the output resistance (R_O) of the emitter follower Q_3 . [10 marks]

Write your answer using pen, in 4 decimal points, with **proper Units** for all the parameters.

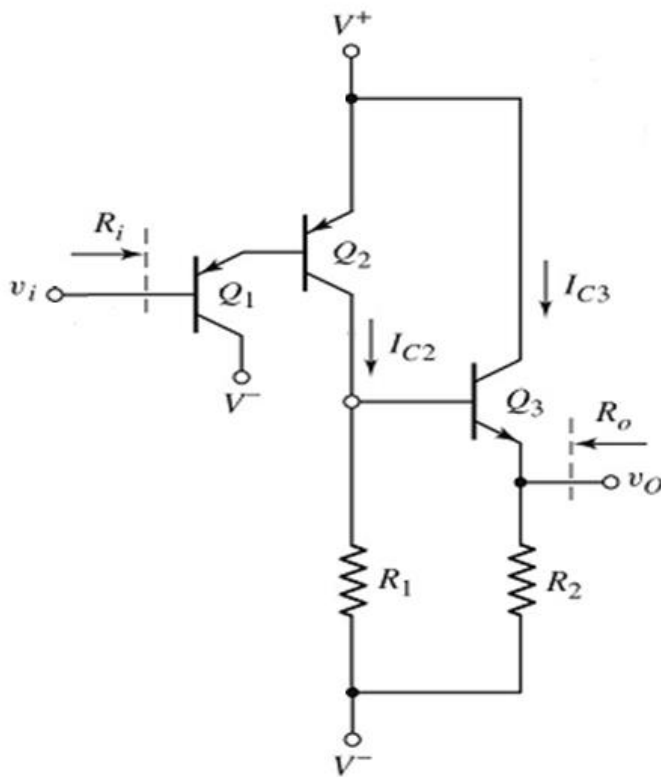

Figure 1

$$i_C = I_S e^{v_{BE}/V_T}; \text{npn}$$

$$i_C = I_S e^{v_{EB}/V_T}; \text{pnp}$$

$$i_C = \alpha i_E = \beta i_B$$

$$i_E = i_B + i_C$$

$$\alpha = \frac{\beta}{\beta + 1}$$

; Small signal

$$\beta = g_m r_\pi$$

$$r_\pi = \frac{\beta V_T}{I_{CQ}}$$

$$g_m = \frac{I_{CQ}}{V_T}$$

$$r_o = \frac{V_A}{I_{CQ}}$$

$$V_T = 26 \text{ mV}$$

R_O	$= R_2 \parallel [(r_{\pi 3} + Z) / (1 + \beta)]$	[1.5]
Z	$= R_1 \parallel R_{c2}$	[1]
R_{c2}	$= r_{o2} = V_A / I_{C2}$	[2]
	$= (120 \text{ V}) / (0.6 \text{ mA}) = 200 \text{ k}\Omega$	[1]
Z	$= (45 \text{ k}\Omega) \parallel (200 \text{ k}\Omega) = 36.735 \text{ k}\Omega$	[1]
$r_{\pi 3}$	$= (\beta V_T) / I_{C3} = (100 \times 0.026) / 1 \text{ m} = 2.6 \text{ k}\Omega$	[2]
R_O	$= (10 \text{ k}\Omega) \parallel [(2.6 \text{ k}\Omega + 36.735 \text{ k}\Omega) / (1 + 100)]$	[1]
	$= 374.85 \Omega$	[0.5]