

Name:
 Student ID Number:
 Section:
 Lecturer: Dr Jamaludin / Dr Jehana Ermy/
 Dr Azni Wati
 Table Number:



College of Engineering
 Department of Electronics and Communication Engineering

Test 2

SEMESTER 2, ACADEMIC YEAR 2016/2017

Subject Code : **EEEB273**
 Course Title : **Electronics Analysis & Design II**
 Date : **31 December 2016**
 Time Allowed : **2 hours**

Instructions to the candidates:

1. Write your Name and Student ID number. Indicate Lecturer for your section. Write your Table Number.
2. Write all your answers using pen. **DO NOT USE PENCIL** except for the diagram.
3. **ANSWER ALL QUESTIONS.**
4. **WRITE YOUR ANSWER ON THIS QUESTION PAPER.**

NOTE: DO NOT OPEN THE QUESTION PAPER UNTIL INSTRUCTED TO DO SO.

☺ **GOOD LUCK!** ☺

Question Number	Q1	Q2	Q3	Total
Marks				

Question 1 [30 marks]

For a MOSFET differential amplifier with cascode active load shown in Figure 1 the circuit parameters are: $V^+ = 5\text{ V}$, $V^- = -5\text{ V}$, and $I_Q = 1.2\text{ mA}$. Transistor parameters for N-MOSFET are: $V_{TN} = 0.7\text{ V}$, $k'_n = 130\ \mu\text{A/V}^2$, $(W/L)_n = 100$ and $\lambda_n = 0.1\text{ V}^{-1}$; and the transistor parameters for P-MOSFET are: $V_{TP} = -0.8\text{ V}$, $k'_p = 35\ \mu\text{A/V}^2$, $(W/L)_p = 200$ and $\lambda_p = 0.2\text{ V}^{-1}$.

- (a) Find the differential-mode voltage gain (A_d) of the differential amplifier with cascode active load. [14 marks]
- (b) Given that the common-mode voltage gain (A_{cm}) for the circuit is **-0.0025**. Calculate the Common-Mode Rejection Ratio (**CMRR**) in dB. [4 marks]
- (c) Calculate the maximum and minimum output voltage at v_o , i.e. $v_o(\text{max})$ and $v_o(\text{min})$. State any assumption used in the calculation. [12 marks]

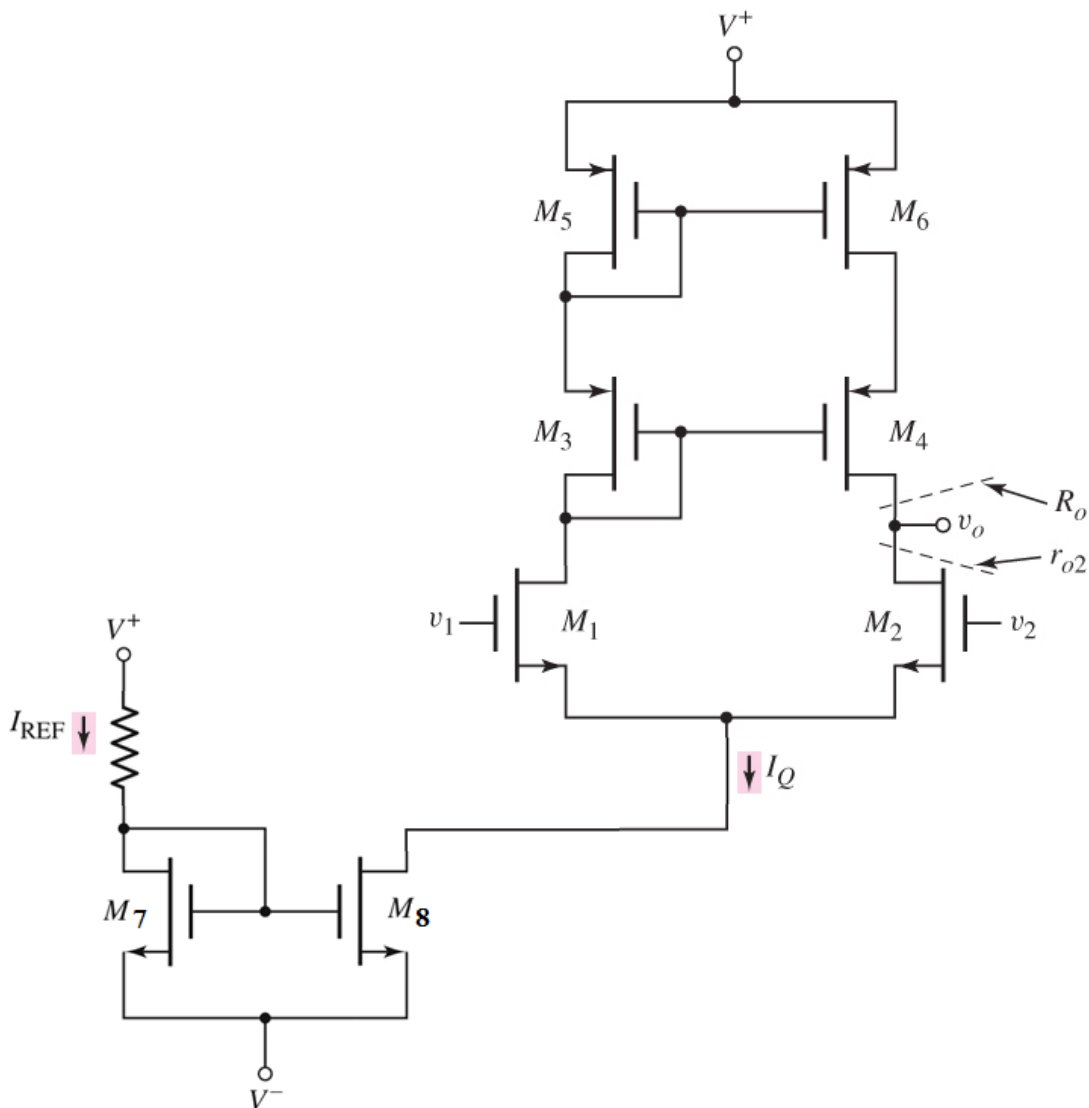

Figure 1

Answer for Question 1

Q1(a)

$$I_{D1} = I_Q / 2 = I_{D2} = I_{D3} = I_{D4} = I_{D5} = I_{D6} = 1.2mA / 2 = 0.6mA \quad [2]$$

$$A_d = g_{m2}(r_{o2} \parallel R_o) \quad [1]$$

$$g_{m2} = 2\sqrt{K_n I_{D2}} = 2\sqrt{\left(\frac{k'_n}{2}\right)\left(\frac{W}{L}\right)_2 I_{D2}}$$

$$g_{m2} = 2\sqrt{\left(\frac{130\mu}{2}\right)(100)(0.6m)} = 3.949mA/V \quad [2]$$

$$r_{o2} = \frac{1}{\lambda_n I_{D2}} = \frac{1}{(0.1)(0.6m)} = 16.667k\Omega \quad [2]$$

$$r_{o4} = \frac{1}{\lambda_p I_{D4}} = \frac{1}{(0.2)(0.6m)} = 8.333k\Omega = r_{o6} \quad [2]$$

$$g_{m4} = 2\sqrt{K_p I_{D4}} = 2\sqrt{\left(\frac{k'_p}{2}\right)\left(\frac{W}{L}\right)_4 I_{D4}}$$

$$g_{m4} = 2\sqrt{\left(\frac{35\mu}{2}\right)(200)(0.5m)} = 2.645mA/V \quad [2]$$

$$R_o = g_{m4} r_{o4} r_{o6} = (2.65m)(8.333k)(8.333k) = 183.7k\Omega \quad [2]$$

$$A_d = (3.949m)(16.667k \parallel 183.7k) = 60.35V/V \quad [1]$$

Q1(b)

$$CMRR = \left| \frac{A_d}{A_{cm}} \right| = \left| \frac{60.35}{-0.0025} \right| = 24140 \quad [2]$$

$$CMRR_{dB} = 20 \log |CMRR| = 20 \log(24140) = 87.65dB \quad [2]$$

Q1(c)

$$V_o(\text{max}) = V^+ - V_{SD6}(\text{sat}) - V_{SD4}(\text{sat}) \quad [1]$$

$$V_{SG4} = V_{SG6} \Rightarrow I_{D4} = \left(\frac{k'_p}{2} \right) \left(\frac{W}{L} \right)_4 (V_{SG4} + V_{TP})^2 \quad [1]$$

$$0.6m = \left(\frac{35\mu}{2} \right) (200) (V_{SG4} + (-0.8))^2 \Rightarrow V_{SG4} = 1.214 \text{ V} \quad [0.5]$$

$$V_{SD4}(\text{sat}) = V_{SG4} + V_{TP} = 1.214 + (-0.8) = 0.414 \text{ V} = V_{SD6}(\text{sat}) \quad [1.5]$$

$$\Rightarrow V_o(\text{max}) = 5 - 2(0.414) = 4.172 \text{ V} \quad [1]$$

$$V_o(\text{min}) = V^- + V_{DS8}(\text{sat}) + V_{DS2}(\text{sat}) \quad [1]$$

$$V_{GS8} \Rightarrow I_{D8} = I_Q = \left(\frac{k'_n}{2} \right) \left(\frac{W}{L} \right)_8 (V_{GS8} - V_{TN})^2 \quad [1]$$

$$1.2m = \left(\frac{130\mu}{2} \right) (100) (V_{GS8} - 0.7)^2 \Rightarrow V_{GS8} = 1.13 \text{ V} \quad [0.5]$$

$$V_{DS8}(\text{sat}) = V_{GS8} - V_{TN} = 1.13 - 0.7 = 0.43 \text{ V} \quad [1]$$

$$V_{GS2} \Rightarrow I_{D2} = \left(\frac{k'_n}{2} \right) \left(\frac{W}{L} \right)_2 (V_{GS2} - V_{TN})^2 \quad [1]$$

$$0.6m = \left(\frac{130\mu}{2} \right) (100) (V_{GS2} - 0.7)^2 \Rightarrow V_{GS2} = 1.004 \text{ V} \quad [0.5]$$

$$V_{DS2}(\text{sat}) = V_{GS2} - V_{TN} = 1.004 - 0.7 = 0.304 \text{ V} \quad [1]$$

$$\Rightarrow V_o(\text{min}) = (-5) + 0.43 + 0.304 = -4.266 \text{ V} \quad [1]$$

Question 2 [30 marks]

The circuit in **Figure 2** shows a simple multi-stage BJT op-amp, consisting of 3 different stages.

It is given that $V_{BE(on)} = 0.6 \text{ V}$, $V_A = 120 \text{ V}$, and $\beta = 120$ for all transistors.

Assume the op-amp is ideal and $I_{C7} = I_Q = 40 \mu\text{A}$. Neglect base currents when calculating quiescent values.

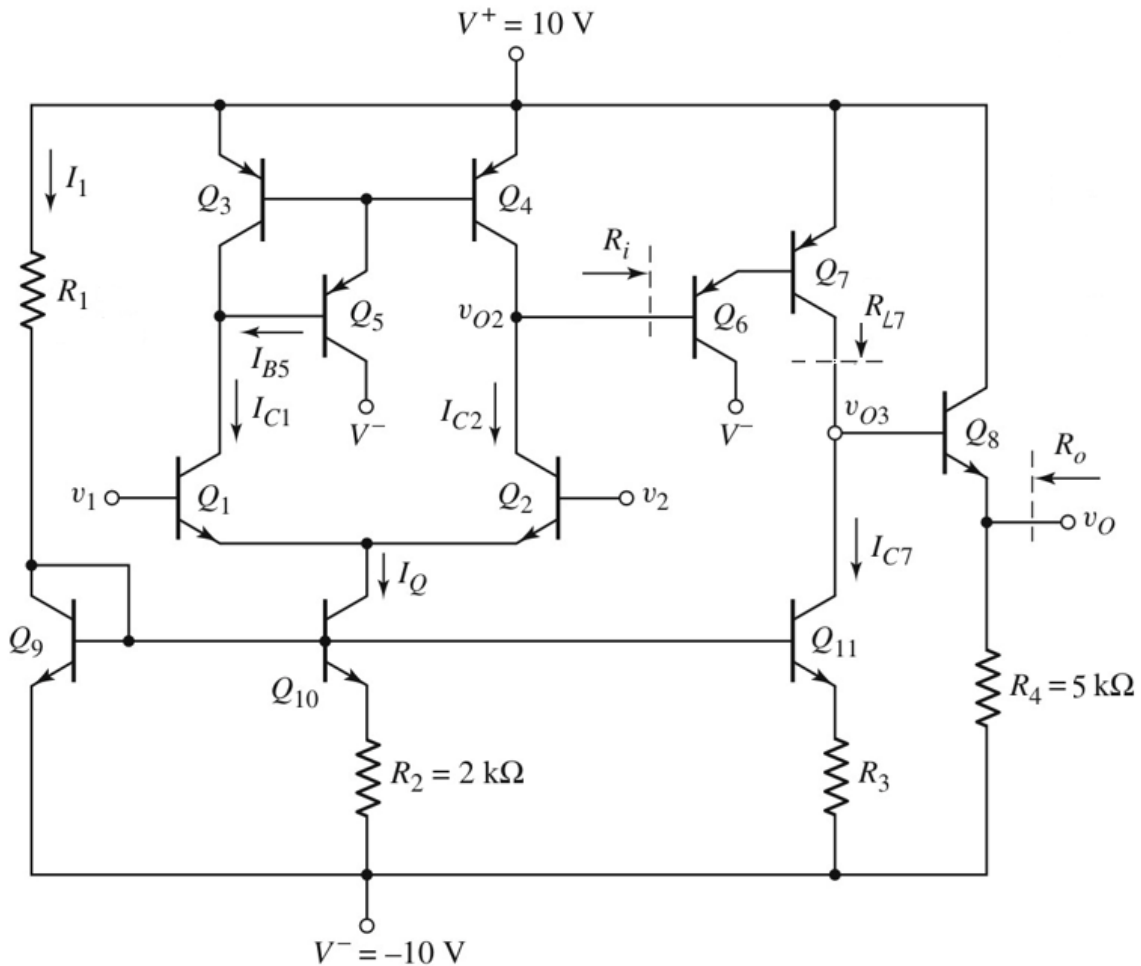

Figure 2

(a) Calculate the input resistance (R_i) and the load resistance (R_{L7}) for the Darlington Pair as indicated in the **Figure 2**. [17 marks]

(b) Calculate the overall differential-mode voltage gain of the op-amp, $A_d = v_o/v_d$. Consider the voltage gain of the gain stage, $A_2 = v_{O3}/v_{O2}$ is derived from the following relationships:

$$v_{O3} = I_{c7} (r_{o7} \parallel R_{L7})$$

$$v_{O2} = I_{b6} R_i$$

[13 marks]

Answer for Question 2

Q2(a)

$$I_{C7} = I_Q = 40\mu A$$

$$I_{C6} = (\beta I_{E6}) / (1 + \beta) = (\beta I_{B7}) / (1 + \beta) = (\beta I_{C7} / \beta) / (1 + \beta) \quad [1]$$

$$I_{C6} = I_{C7} / (1 + \beta) = 40\mu / 121 = 0.3305\mu A \quad [1]$$

$$r_{\pi6} = \beta V_T / I_{C6} = (120 \times 0.026) / 0.3305\mu = 9.44M\Omega \quad [1]$$

$$r_{\pi7} = \beta V_T / I_{C7} = (120 \times 0.026) / 40\mu = 78k\Omega \quad [1]$$

$$R_i = r_{\pi6} + r_{\pi7}(1 + \beta) = 9.44M + 78k(121) = 18.878M\Omega \quad [2]$$

$$R_i = \frac{2(1 + \beta)\beta V_T}{I_Q} = \frac{2 \times 121 \times 120 \times 0.026}{40\mu} = 18.876M\Omega \quad [\text{Option} = 6 \text{ marks}]$$

$$R_{c11} = r_{o11}[1 + g_{m11}(r_{\pi11} \parallel R_3)] \quad [1]$$

$$R_3 = R_2 = 2k\Omega \quad [1]$$

$$r_{o11} = V_A / I_{C7} = 120 / 40\mu = 3M\Omega \quad [0.5]$$

$$r_{\pi11} = \beta V_T / I_{C7} = 120 \times 0.026 / 40\mu = 78k\Omega \quad [05]$$

$$g_{m11} = I_{C7} / V_T = 40\mu / 0.026 = 1.538mA/V \quad [1]$$

$$R_{c11} = 3M[1 + (1.538m)(78k \parallel 2k)] = 1.99M\Omega \quad [1]$$

[Total for $R_{c11} = 5$ marks]

$$I_{C8} = (v_O - V^-) / R_4 = (0 - (-10)) / 5k = 2mA \quad [1]$$

$$R_{b8} = r_{\pi8} + (1 + \beta)R_4 \quad [1]$$

$$R_4 = 5k\Omega$$

$$r_{\pi8} = \beta V_T / I_{C8} = 120 \times 0.026 / 2m = 1.56k\Omega \quad [1]$$

$$\rightarrow R_{b8} = 606.56k\Omega \quad [1]$$

[Total for $R_{b8} = 4$ marks]

$$R_{L7} = R_{c11} \parallel R_{b8} \quad [1]$$

$$\rightarrow R_{L7} = 1.99M \parallel 606.6k = 577.35k\Omega \quad [1]$$

[Total for $R_{L7} = 2$ marks]

Q2(b)

From previous calculations :

$$I_{C7} = I_Q = 40\mu A$$

$$R_i = 18.876M\Omega$$

$$R_{L7} = 577.35k\Omega$$

$$I_{C2} = I_{C4} = I_Q / 2 = 20\mu A \quad [1]$$

$$g_{m2} = I_{C2} / V_T = 20\mu / 0.026 = 0.769mA/V \quad [1]$$

$$r_{o2} = V_A / I_{C2} = 120 / 20\mu = 6M\Omega \quad [0.5]$$

$$r_{o4} = V_A / I_{C4} = 120 / 20\mu = 6M\Omega \quad [0.5]$$

$$A_{d1} = g_{m2}(r_{o2} \parallel r_{o4} \parallel R_i) \quad [1]$$

$$\rightarrow A_{d1} = 0.769m(2.588M) = 1990 \quad [1]$$

$$v_{o3} = I_{c7}(r_{o7} \parallel R_{L7}) = (\beta I_{b7})(r_{o7} \parallel R_{L7}) = \beta(1 + \beta)I_{b6}(r_{o7} \parallel R_{L7}) \quad [1]$$

$$v_{o2} = I_{b6}R_i$$

$$A_2 = \frac{v_{o3}}{v_{o2}} = \frac{\beta(1 + \beta)(r_{o7} \parallel R_{L7})}{R_i} \quad [1]$$

$$r_{o7} = V_A / I_{C7} = 120 / 40\mu = 3M\Omega \quad [1]$$

$$(r_{o7} \parallel R_{L7}) = 3M \parallel 577.35k = 402.5k\Omega$$

$$\rightarrow A_2 = \frac{120 \times 121 \times 402.5k}{18.876M} = 309.6 \quad [1]$$

$$A_3 = 1 \quad [1]$$

$$\text{Overall Gain, } A_d = A_{d1} \times A_2 \times A_1 \quad [2]$$

$$\rightarrow A_d = 1990 \times 309.6 \times 1 = 616134 \quad [1]$$

Question 3 [40 marks]

- (a) Compare the performance of both **Class A** and **Class B** output stage in terms of **power conversion efficiency, η** . [5 marks]
- (b) Describe the **crossover distortion** experienced in **Class B** output stage and **explain** how the **crossover distortion** can be **eliminated**. [5 marks]
- (c) Consider the **Class A emitter-follower** circuit shown in **Figure 3**. Assume all transistors are matched with $V_{BE(on)} = 0.6 \text{ V}$, $V_{CE(sat)} = 0.2 \text{ V}$, and $V_A = \infty$. **Neglect** base currents.

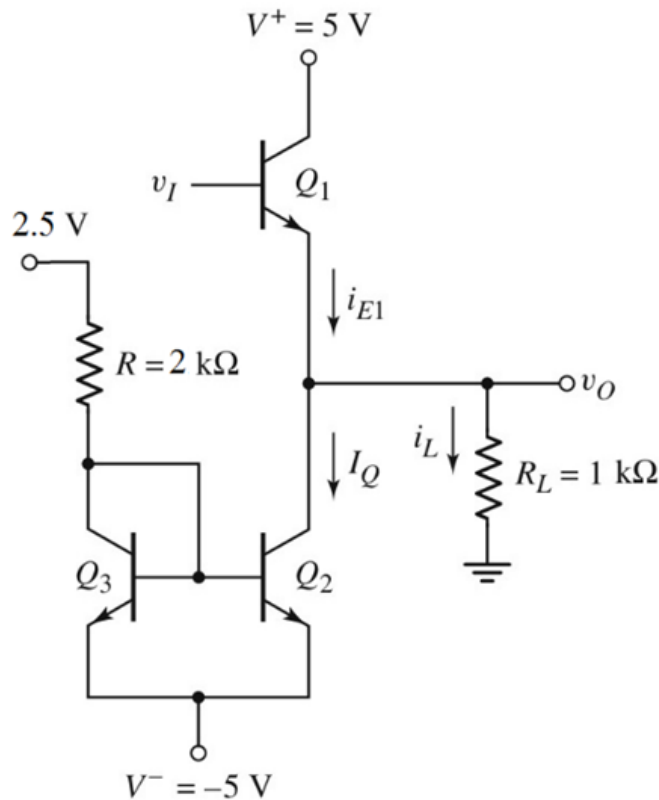

Figure 3

- (i) Find the value of I_Q . [5 marks]
- (ii) Determine the maximum and minimum values of **input voltage** for the circuit to operate in the linear region. [10 marks]
- (iii) For $v_O = 0 \text{ V}$, calculate the power dissipated in the transistor Q_1 and the power dissipated in the current source (Q_2 , Q_3 , and R). [8 marks]
- (iv) Determine the power conversion efficiency (η) for a symmetrical sine-wave output voltage (v_O) with peak value of 4 V . [7 marks]

Answer for Question 3

- (a) Class A has low power conversion efficiency where its maximum efficiency is 25% [2.5] while Class B can reach up to 78.5% although suffering from cross-over distortion [2.5].
- (b) For a complementary push-pull output stage in Class B, both transistors are cut off [1] and v_O is 0 in the dead band portion [0.5]. A not perfect sinusoidal signal means that crossover distortion is produced by the dead band region [1.5]. Crossover distortion in Class B can be virtually eliminated by applying a small quiescent bias on each output transistor for a zero input signal. This creates a class-AB output stage. [2]

(c) Class A emitter-follower circuit

$$\begin{aligned} \text{(i)} \quad I_Q &= (V^+ - v_{BE(on)} - V^-) / R && [2] \\ &= (2.5 - 0.6 + 5) / 2k && [2] \\ &= \underline{\underline{3.450 \text{ mA}}} && [1] \end{aligned}$$

$$\begin{aligned} \text{(ii)} \quad v_I(max) &= v_O(max) + v_{BE(on)} && [2] \\ v_O(max) &= V^+ - v_{CE1(sat)} = 5 - 0.2 = 4.8 \text{ V} && [2] \\ \text{So, } v_I(max) &= 4.8 + 0.6 = \underline{\underline{5.4 \text{ V}}} && [1] \end{aligned}$$

$$\begin{aligned} v_I(min) &= v_O(min) + v_{BE(on)} && [2] \\ &= [i_L(min)R_L + v_{BE(on)}] && [1] \\ i_L(min) &= -I_Q = -3.450 \text{ mA} && [1] \\ v_I(min) &= (-3.450\text{m})(1k) + 0.6 = \underline{\underline{-2.850 \text{ V}}} && [1] \end{aligned}$$

$$\begin{aligned} \text{(iii)} \quad P_{Q1} &= I_{C1} \cdot v_{CE1} && [1] \\ &= I_Q \cdot v_{CE1} = (3.450\text{m})(5) = \underline{\underline{17.25 \text{ mW}}} && [1] \end{aligned}$$

$$\begin{aligned} P_{Q2} &= I_{C2} \cdot v_{CE2} && [1] \\ &= I_Q \cdot v_{CE2} = (3.450\text{m})(0 - (-5)) = \underline{\underline{17.25 \text{ mW}}} && [1] \end{aligned}$$

$$\begin{aligned} P_{Q3} &= I_{C3} \cdot v_{CE3} && [1] \\ &= I_Q \cdot v_{BE(on)} = (3.450\text{m})(0.6) = \underline{\underline{2.070 \text{ mW}}} && [1] \end{aligned}$$

$$\begin{aligned} P_R &= I^2 R && [1] \\ &= (3.450\text{m})^2 (2k) = \underline{\underline{0.0238 \text{ mW}}} && [1] \end{aligned}$$

- (iv) With peak value of 4 V.

$$\begin{aligned} \text{Power conversion efficiency, } \eta &= P_L / P_S \times 100\% && [2] \\ P_L &= 0.5(V_p)^2 / R_L = 0.5 (4)^2 / 1k = \underline{\underline{8 \text{ mW}}} && [2] \\ P_S &= (V^+ - V^-) 2I_Q = (5 - (-5))(3.45\text{m}) + (2.5 - (-5))(3.45\text{m}) = \underline{\underline{60.375 \text{ mW}}} && [2] \\ \eta &= 8\text{m} / 60.375\text{m} \times 100\% = \underline{\underline{13.25\%}} && [1] \end{aligned}$$

BASIC FORMULA FOR TRANSISTOR

BJT

$$i_C = I_S e^{v_{BE}/V_T}; \text{npn}$$

$$i_C = I_S e^{v_{EB}/V_T}; \text{pnp}$$

$$i_C = \alpha i_E = \beta i_B$$

$$i_E = i_B + i_C$$

$$\alpha = \frac{\beta}{\beta + 1}$$

; Small signal

$$\beta = g_m r_\pi$$

$$g_m = \frac{I_{CQ}}{V_T}$$

$$r_\pi = \frac{\beta V_T}{I_{CQ}}$$

$$r_o = \frac{V_A}{I_{CQ}}$$

$$V_T = 26 \text{ mV}$$

MOSFET

; N – MOSFET

$$v_{DS}(\text{sat}) = v_{GS} - V_{TN}$$

$$i_D = K_n [v_{GS} - V_{TN}]^2$$

$$K_n = \frac{k'_n}{2} \cdot \frac{W}{L}$$

; P – MOSFET

$$v_{SD}(\text{sat}) = v_{SG} + V_{TP}$$

$$i_D = K_p [v_{SG} + V_{TP}]^2$$

$$K_p = \frac{k'_p}{2} \cdot \frac{W}{L}$$

; Small signal

$$g_m = 2\sqrt{K_n I_{DQ}}$$

$$r_o \cong \frac{1}{\lambda I_{DQ}}$$