

**Question:**

Consider the BJT differential amplifier in **Figure 1**. Transistors are matched. The circuit and transistor parameters are  $I_Q = 1 \text{ mA}$ ,  $\beta = 100$ , and  $V_A = \infty$ .

- (a) **Design** the circuit such that one-sided differential-mode output voltage taken at  $v_{C2} = 8 \text{ V}$  when a differential-mode input voltage of  $v_d = 0.05 \text{ V}$  is applied. [7 marks]
- (b) **Determine** the differential-mode input resistance,  $R_{id}$ . [3 marks]

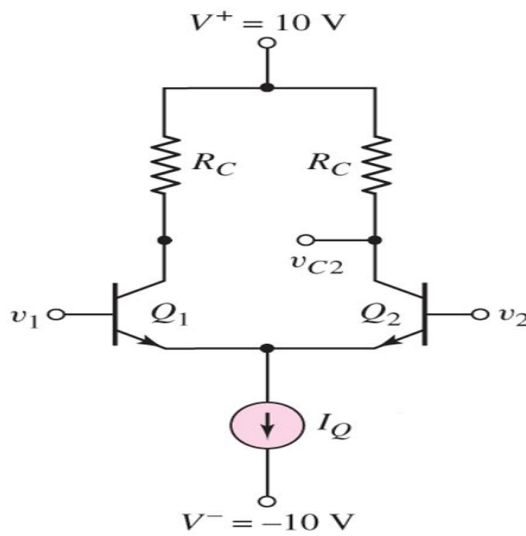

**Figure 1**

**Answer:**

- (a) The differential-mode voltage gain is given by

$$A_d = \frac{v_o}{v_d} = \frac{g_{m2} R_C}{2} \quad [2]$$

$$g_{m2} = \frac{I_{CQ2}}{V_T} = \frac{I_Q / 2}{V_T} = \frac{0.5 \text{ mA}}{26 \text{ mV}} = 19.231 \text{ mA/V} \quad [2]$$

$$A_d = \frac{v_o}{v_d} = \frac{8}{0.05} = \frac{g_{m2} R_C}{2} = \frac{(19.231 \text{ m}) R_C}{2} \quad [2]$$

$$\Rightarrow R_C = \frac{320}{19.231 \text{ m}} = 16.64 \text{ k}\Omega \quad [1]$$

- (b)  $R_{id} = 2r_\pi = \frac{2\beta V_T}{I_{CQ}} = \frac{2 \times 100 \times 0.026}{0.5 \text{ mA}} = 10.4 \text{ k}\Omega \quad [1, 1, 1]$

$$i_C = I_S e^{v_{BE}/V_T}; \text{ npn}$$

$$i_C = I_S e^{v_{EB}/V_T}; \text{ pnp}$$

$$i_C = \alpha i_E = \beta i_B$$

$$i_E = i_B + i_C$$

$$\alpha = \frac{\beta}{\beta + 1}$$

; Small signal

$$\beta = g_m r_\pi$$

$$g_m = \frac{I_{CQ}}{V_T}$$

$$r_\pi = \frac{\beta V_T}{I_{CQ}}$$

$$r_o = \frac{V_A}{I_{CQ}}$$

$$V_T = 26 \text{ mV}$$

**Question:**

Consider the BJT differential amplifier in **Figure 1**. Transistors are matched. The circuit and transistor parameters are  $I_Q = 1.1 \text{ mA}$ ,  $\beta = 100$ , and  $V_A = \infty$ .

- (a) **Design** the circuit such that one-sided differential-mode output voltage taken at  $v_{C2} = 7.9 \text{ V}$  when a differential-mode input voltage of  $v_d = 0.05 \text{ V}$  is applied. [7 marks]
- (b) **Determine** the differential-mode input resistance,  $R_{id}$ . [3 marks]

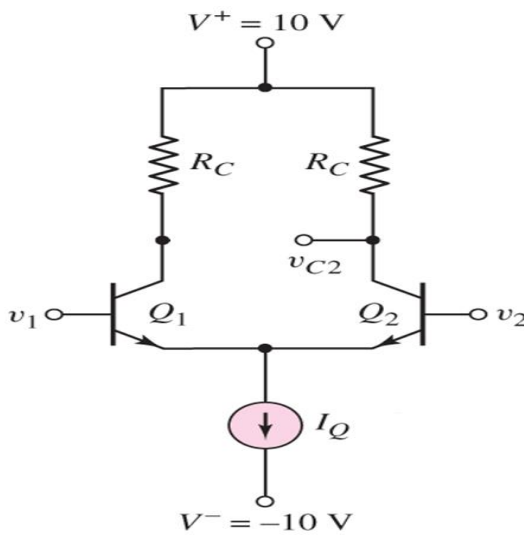

**Figure 1**

**Answer:**

- (a) The differential-mode voltage gain is given by

$$A_d = \frac{v_o}{v_d} = \frac{g_{m2} R_C}{2} \quad [2]$$

$$g_{m2} = \frac{I_{CQ2}}{V_T} = \frac{I_Q / 2}{V_T} = \frac{0.55 \text{ mA}}{26 \text{ mV}} = 21.153 \text{ mA/V} \quad [2]$$

$$A_d = \frac{v_o}{v_d} = \frac{7.9}{0.05} = \frac{g_{m2} R_C}{2} = \frac{(21.153 \text{ mA}) R_C}{2} \quad [2]$$

$$\Rightarrow R_C = \frac{316}{21.153 \text{ mA}} = 14.938 \text{ k}\Omega \quad [1]$$

(b)  $R_{id} = 2r_\pi = \frac{2\beta V_T}{I_{CQ}} = \frac{2 \times 100 \times 0.026}{0.55 \text{ mA}} = 9.45 \text{ k}\Omega \quad [1, 1, 1]$

$$i_C = I_S e^{v_{BE}/V_T}; \text{ npn}$$

$$i_C = I_S e^{v_{EB}/V_T}; \text{ pnp}$$

$$i_C = \alpha i_E = \beta i_B$$

$$i_E = i_B + i_C$$

$$\alpha = \frac{\beta}{\beta + 1}$$

; Small signal

$$\beta = g_m r_\pi$$

$$g_m = \frac{I_{CQ}}{V_T}$$

$$r_\pi = \frac{\beta V_T}{I_{CQ}}$$

$$r_o = \frac{V_A}{I_{CQ}}$$

$$V_T = 26 \text{ mV}$$

**Question:**

Consider the BJT differential amplifier in **Figure 1**. Transistors are matched. The circuit and transistor parameters are  $I_Q = 0.9 \text{ mA}$ ,  $\beta = 100$ , and  $V_A = \infty$ .

- (a) **Design** the circuit such that one-sided differential-mode output voltage taken at  $v_{C2} = 8.1 \text{ V}$  when a differential-mode input voltage of  $v_d = 0.05 \text{ V}$  is applied. [7 marks]
- (b) **Determine** the differential-mode input resistance,  $R_{id}$ . [3 marks]

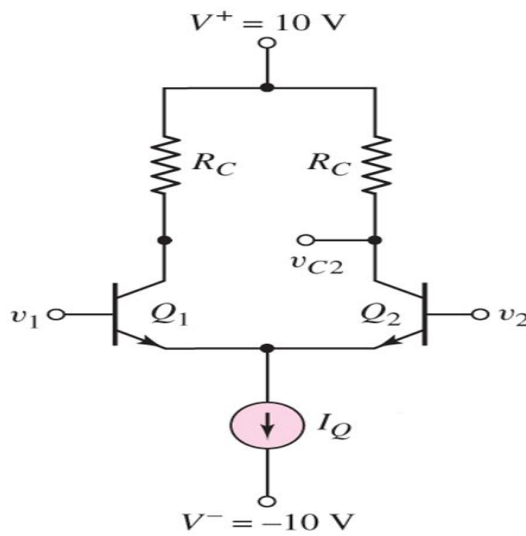

**Figure 1**

**Answer:**

- (a) The differential-mode voltage gain is given by

$$A_d = \frac{v_o}{v_d} = \frac{g_{m2} R_C}{2} \quad [2]$$

$$g_{m2} = \frac{I_{CQ2}}{V_T} = \frac{I_Q / 2}{V_T} = \frac{0.45 \text{ mA}}{26 \text{ mV}} = 17.307 \text{ mA/V} \quad [2]$$

$$A_d = \frac{v_o}{v_d} = \frac{8.1}{0.05} = \frac{g_{m2} R_C}{2} = \frac{(17.307 \text{ m}) R_C}{2} \quad [2]$$

$$\Rightarrow R_C = \frac{324}{17.307 \text{ m}} = 18.72 \text{ k}\Omega \quad [1]$$

- (b)  $R_{id} = 2r_\pi = \frac{2\beta V_T}{I_{CQ}} = \frac{2 \times 100 \times 0.026}{0.45 \text{ mA}} = 11.55 \text{ k}\Omega \quad [1,1,1]$

$$i_C = I_S e^{v_{BE}/V_T}; \text{ npn}$$

$$i_C = I_S e^{v_{EB}/V_T}; \text{ pnp}$$

$$i_C = \alpha i_E = \beta i_B$$

$$i_E = i_B + i_C$$

$$\alpha = \frac{\beta}{\beta + 1}$$

; Small signal

$$\beta = g_m r_\pi$$

$$g_m = \frac{I_{CQ}}{V_T}$$

$$r_\pi = \frac{\beta V_T}{I_{CQ}}$$

$$r_o = \frac{V_A}{I_{CQ}}$$

$$V_T = 26 \text{ mV}$$

**Question:**

Consider the BJT differential amplifier in **Figure 1**. Transistors are matched. The circuit and transistor parameters are  $I_Q = 1.2 \text{ mA}$ ,  $\beta = 100$ , and  $V_A = \infty$ .

- (a) **Design** the circuit such that one-sided differential-mode output voltage taken at  $v_{C2} = 7.8 \text{ V}$  when a differential-mode input voltage of  $v_d = 0.05 \text{ V}$  is applied. [7 marks]
- (b) **Determine** the differential-mode input resistance,  $R_{id}$ . [3 marks]

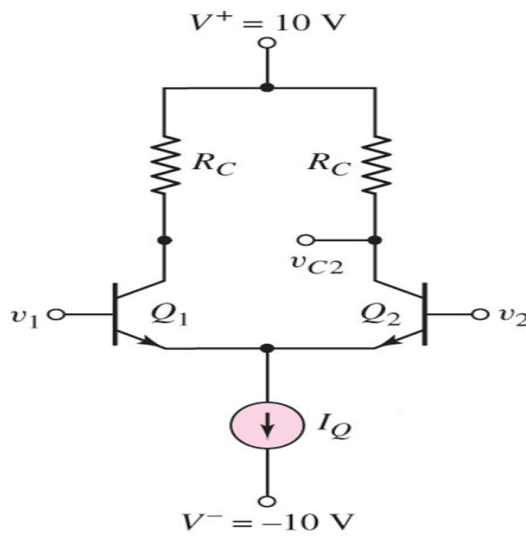

**Figure 1**

**Answer:**

- (a) The differential-mode voltage gain is given by

$$A_d = \frac{v_o}{v_d} = \frac{g_{m2} R_C}{2} \quad [2]$$

$$g_{m2} = \frac{I_{CQ2}}{V_T} = \frac{I_Q / 2}{V_T} = \frac{0.6 \text{ mA}}{26 \text{ mV}} = 23.076 \text{ mA/V} \quad [2]$$

$$A_d = \frac{v_o}{v_d} = \frac{7.8}{0.05} = \frac{g_{m2} R_C}{2} = \frac{(23.076 \text{ m}) R_C}{2} \quad [2]$$

$$\Rightarrow R_C = \frac{312}{23.076 \text{ m}} = 13.52 \text{ k}\Omega \quad [1]$$

- (b)  $R_{id} = 2r_\pi = \frac{2\beta V_T}{I_{CQ}} = \frac{2 \times 100 \times 0.026}{0.6 \text{ mA}} = 8.67 \text{ k}\Omega \quad [1,1,1]$

$$i_C = I_S e^{v_{BE}/V_T}; \text{ npn}$$

$$i_C = I_S e^{v_{EB}/V_T}; \text{ pnp}$$

$$i_C = \alpha i_E = \beta i_B$$

$$i_E = i_B + i_C$$

$$\alpha = \frac{\beta}{\beta + 1}$$

; Small signal

$$\beta = g_m r_\pi$$

$$g_m = \frac{I_{CQ}}{V_T}$$

$$r_\pi = \frac{\beta V_T}{I_{CQ}}$$

$$r_o = \frac{V_A}{I_{CQ}}$$

$$V_T = 26 \text{ mV}$$